

Instruction Manual

AC Service Station

Please read this manual carefully before installing and using.
Follow the warnings and precautions marked in the product manual.



1. Instruction.....	2	ii.)Recovery.....	14
1.) Safety Precautions.....	2	iii) Vacuum.....	15
2.) Safety Signs.....	2	iv.) Charge.....	15
2.Product Introductions.....	3	9. Database search.....	18
1.) Features	3	10. Maintenance.....	19
2.) Technical specification.....	3	1.) Change the filter.....	19
3.) Appearance.....	4	2.) Change Vacuum Pump Oil.....	19
3. How to connect the equipment.....	5	3.) Calibrate the scale.....	20
4. Initial setup.....	6	4.) Unit Leak check.....	21
5. Operating Instructions.....	8	5.) Tank Clean	22
6. A/C Pressure check.....	8	6.) Air purge Manual	22
7. Fully-Automatic Operation.....	10	11. SETTING.....	23
8. Manual operation.....	13	12. Troubleshooting.....	24
i.)Flushing.....	13		

Note: Please take a picture of the nameplate on the upper left side of the machine and save it after unpacking.

1. Instruction:

1.) Safety Precautions

i. **ALLOW ONLY QUALIFIED PERSONNEL TO OPERATE THE MACHINE.** Before operation, read and follow the instructions and warnings in this manual. The operator must have knowledge about air conditioning and refrigeration systems, refrigerants, and the dangers of pressurized components. If the operator cannot read this manual, operating instructions and safety precautions must be read and discussed in the operator's native language.

ii. **USE THE MACHINE AS OUTLINED IN THIS MANUAL.** Using the machine in a manner for which it was not designed will compromise the machine and nullify the protections provided.

iii. **AVOID BREATHING IN A/C REFRIGERANT OR LUBRICANT VAPOR OR MIST.** Exposure can irritate eyes, nose, and throat. To remove refrigerant from the A/C system, use only equipment certified for the type of refrigerant being removed. Use the unit in locations with mechanical ventilation that provides at least four times ventilation per hour. If accidental system discharge occurs, ventilate the work area before resuming service.

IV. **TO REDUCE THE RISK OF FIRE,** do not use the machine in the vicinity of spilled or open containers of gasoline or other flammable substances. Do not use an extension cord. Do not use the machine in the vicinity of flames and hot surfaces. Refrigerant can decompose at high temperatures and free toxic substances to the environment that can be noxious to the user.

Do not use the machine in environments containing explosive gases or vapors. Do not use this machine in ATEX classified zones or areas. Protect the machine from conditions that can cause electrical failure or other hazards relating to ambient interaction.

V. **DO NOT PRESSURE TEST OR LEAK TEST EQUIPMENT AND/OR VEHICLE AIR CONDITIONING SYSTEMS WITH COMPRESSED AIR.** Mixtures of air and R1234yf refrigerant can be combustible at elevated pressures. These mixtures are potentially dangerous and can result in fire or explosion causing personal injury and/or property damage.







VI. **NEVER START THE MACHINE IF IT WILL NOT BE USED IMMEDIATELY.** Disconnect the electrical supply before a long period of inactivity or before internal maintenance is performed.

DO NOT MODIFY THE PRESSURE RELIEF VALVE OR CHANGE THE CONTROL SYSTEM SETTINGS. Using the machine in a manner for which it was not designed will compromise the machine and nullify the protections provided.

VII. **HOSES CAN CONTAIN LIQUID REFRIGERANT UNDER PRESSURE.** Contact with refrigerant can cause personal injury, including blindness and frozen skin. Wear protective equipment, including goggles and gloves. Disconnect hoses using extreme caution. Ensure the phase is complete before disconnecting the machine to prevent the release of refrigeration to the atmosphere.

VIII. PRESSURIZED TANK CONTAINS LIQUID REFRIGERANT. Do not overfill the internal storage vessel (ISV). Overfilling can cause explosion resulting in personal injury or death. Do not recover refrigerants into nonrefillable containers; use only type-approved refillable containers that have pressure relief valves. .

2.) Safety Signs on the Machine

	<p>Carefully read the instructions.</p>
	<p>Do not use in open air in case of rain or high humidity.</p>
	<p>Wear gloves.</p>
	<p>Wear protection goggles.</p>
	<p>Grounding protection.</p>
	<p>Electrical shock hazard.</p>

2 Product introduction

1.) Features:

- Fully automatic operation; 7 inches touch screen, digital pressure gauges assembly, 5 electronic scales for the weight measurement of refrigerant, PAG oil, POE oil, used oil);
- Vehicle compatible: Gasoline/Diesel car, electric car, hybrid car;
- The unique exclusive flushing function, cleans the A/C system and drain used compressor oil. Equipped with a sight glass, the whole process of the cleaning state is visual.
- Tank or mini cans quantitative charge for optional.
- Benefit from the deep recovery program, recovery efficiency is up to 95%;
- HP/LP/HP+LP charge mode is select-able, automatic compensation for charging;
- Sealed oils bottles which prevent the oil from becoming contaminated by air and humidity;
- Up to 60000 vehicle A/C service data base, addable and editable by SD card. up to 20000 vehicle A/C service data base, addable and editable by SD card;
- Automatic management for filter changing and vacuum pump oil changing;;

2.) Technical Specifications:

Refrigerant:	R134a
Power Supply:	220V 50HZ
Power Consumption:	1200W
Unit Operating Temperature Range:	-20°C ~ +60°C
Display:	7" touch screen
Oil bottle:	300ml (3 Sealed oil bottle, PAG/POE/Used oi)
Electronic Scales::	5
Scale accuracy: :	10g
Recovery efficiency::	95% above
Recovery ability:	2/3HP
Vacuum ability:	-1bar/15min
Refrigerant Tank Capacity:	18kg
Filter Capacity:	100kg
Dimensions	:
1080mm(Height)*630mm(Depth)*680mm(Width)	
Weight:	95kg

3.) Product appearance

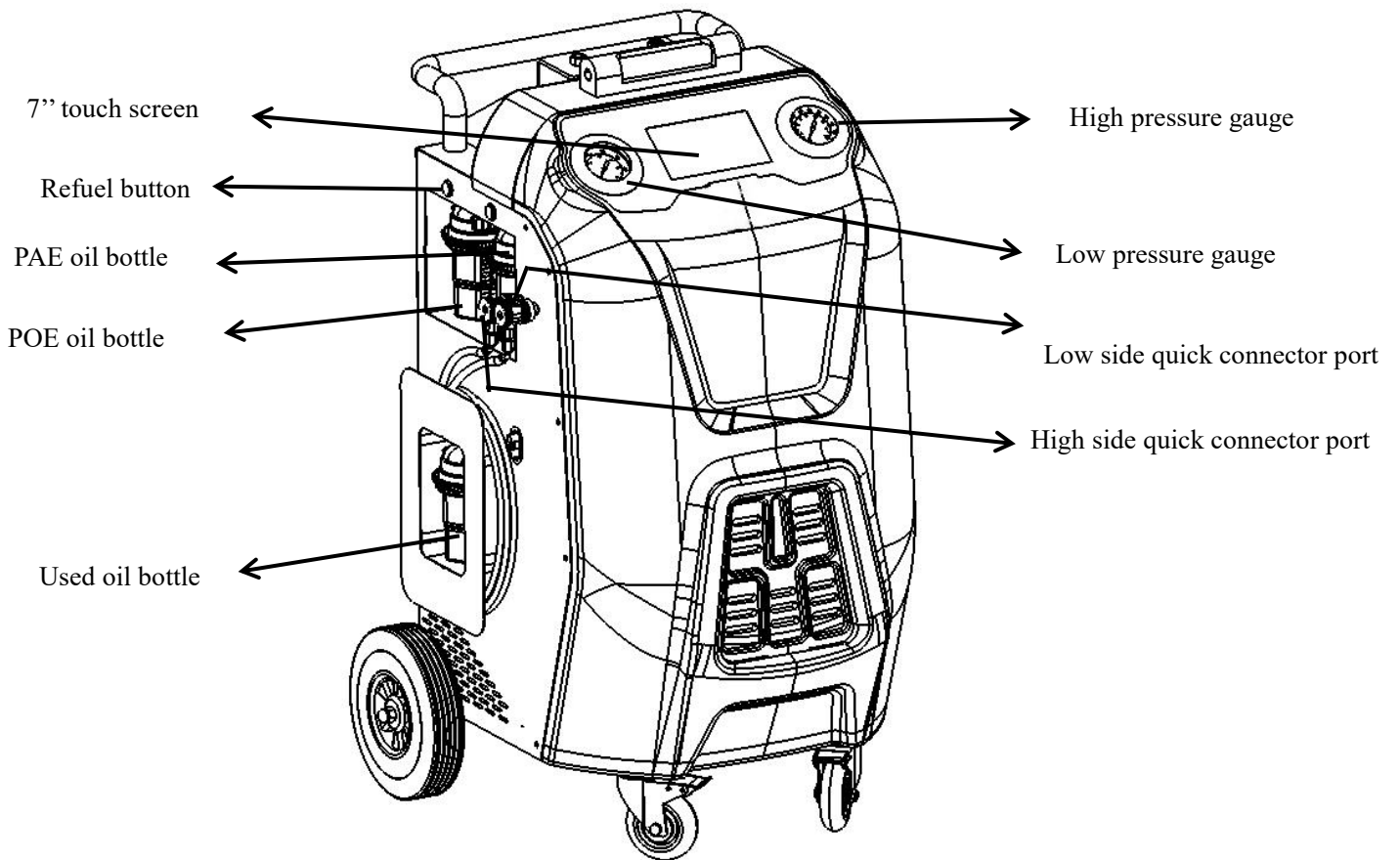
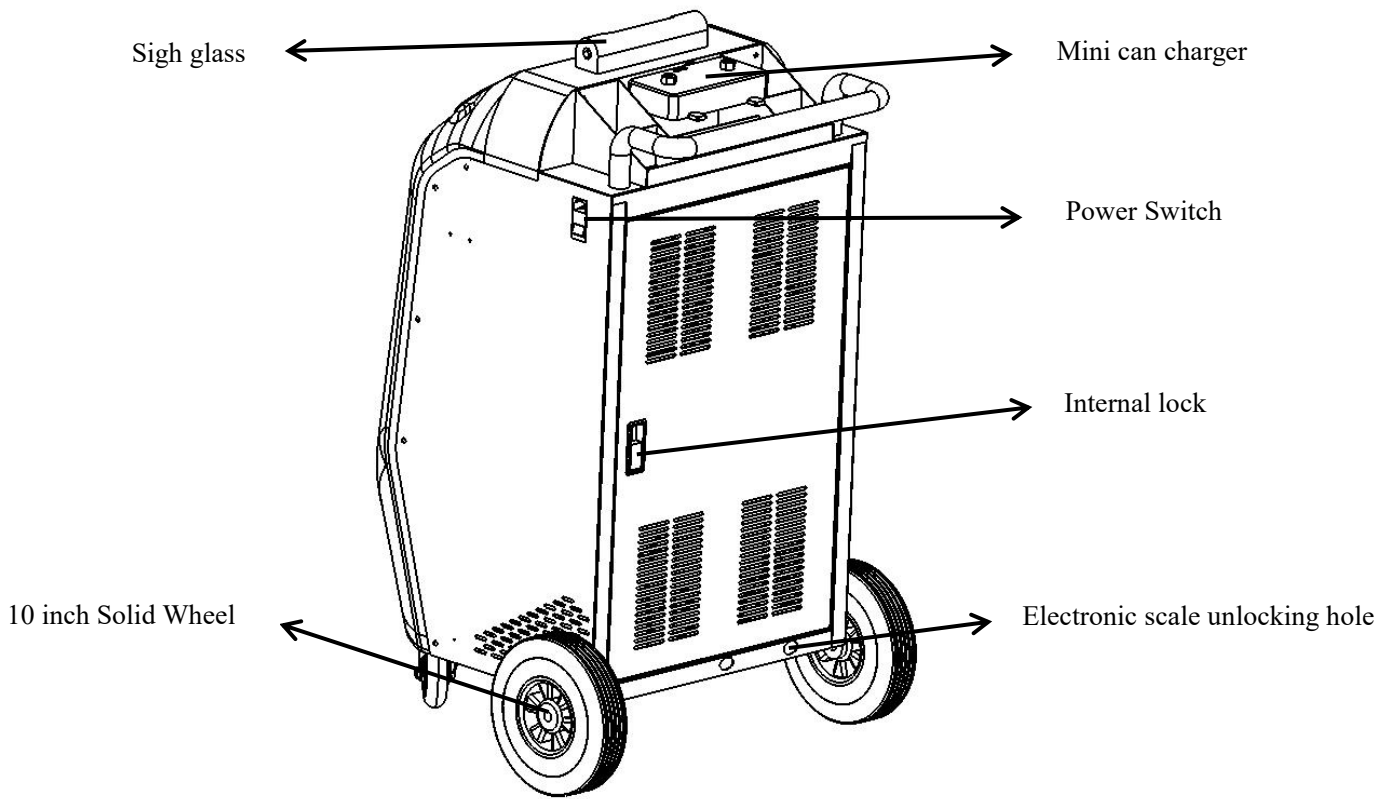

3. How to connect the equipment:

- 1.) Connect the red and blue quick connectors to the red and blue service hoses.
- 2.) Connect the high-side (red) and low-side (blue) service hoses to the vehicle A/C system.

High and low side valve operation guidelines

During the operation, the system will prompt "close high and low side valves" and "open high and low side valves" for many times, which means:

“Close high and low side valves” :

As shown in the picture, tighten the high and low side valves counterclockwise, which is the opposite direction of the arrows on the high and low side valves (arrows marked "open").

Close the A/C system quick connector

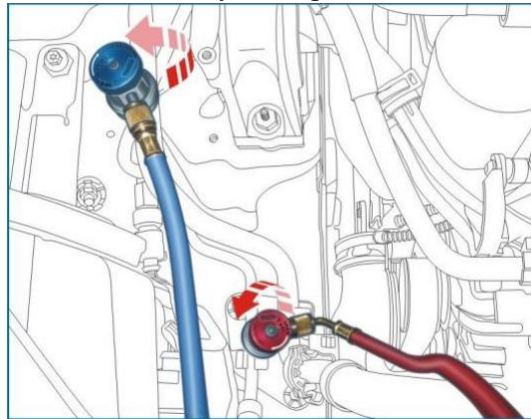

Tighten the A/C system quick-connector counterclockwise

“Open the high and low side valves” :

As shown in the picture, tighten the high and low side valves clockwise, which is the direction of the arrows on the high and low side valves (arrows marked "open")

Open the A/C system quick connector

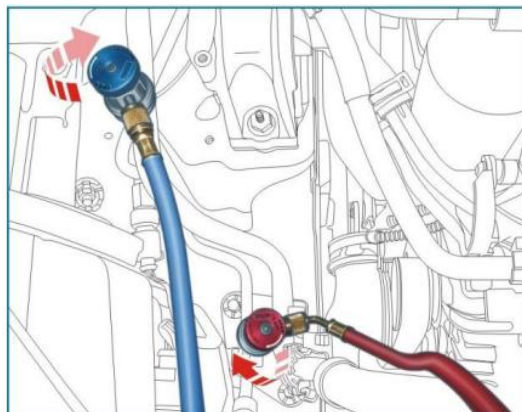

Tighten the A/C system quick-connector clockwise

4. Initial Setup

For the first time use, please follow the prompts to complete the initial setup.

Unlock the electronic scale

1)Open the door at the rear of the device to find the electronic scale protection device as shown in the picture.

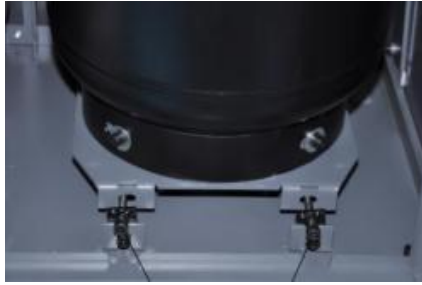

Unlock screw

2)Unscrew the screw and unlock it from the lock hole of the weighing pan.otherwise it will be in a malfunctioning state.

Tank Filling

There is no refrigerant in internal tank, it must be filled with refrigerant before use.Add 3-6kg of refrigerant, method is as follows:

A)、From MENU, select PAG or POE to enter the next step..

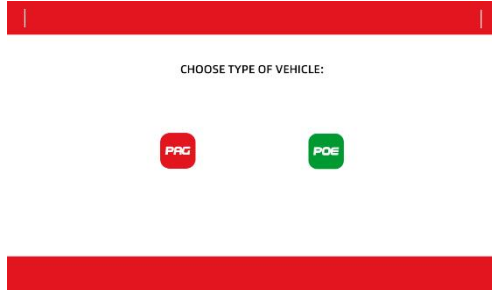

B)、 From MENU,click”Setting”

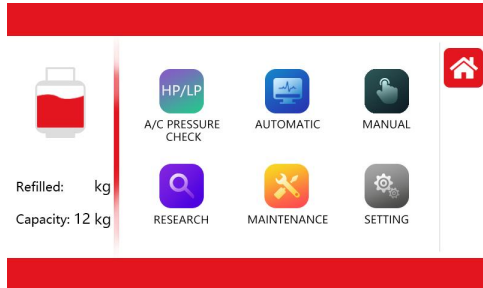

C)、 Select the“Tank Filling”.

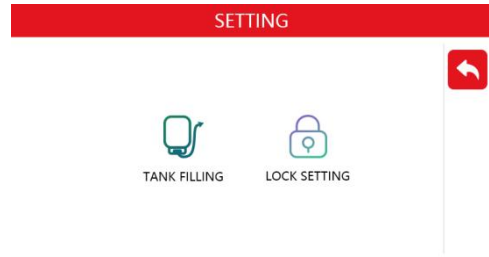

D)Enter the desired tank fill amount,Click to enter next step.



E)Operate according to the prompts , Click to continue.

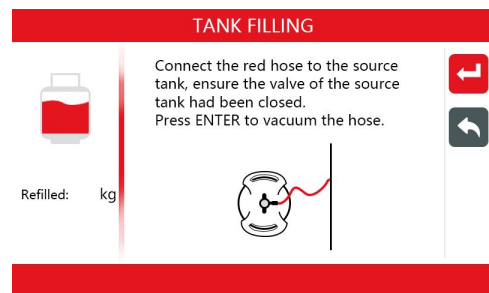

F)Vacuuming the hose,please wait.



G)Operate according to the system prompts, Click to continue.

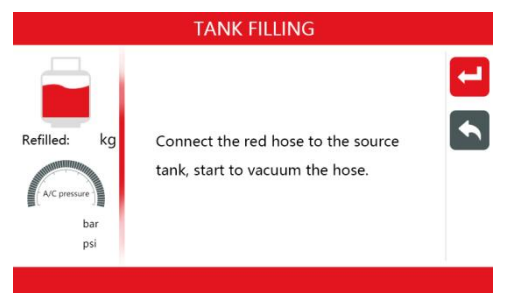

H) Vacuum completed, operate according to the

prompts, Click  to enter next step.

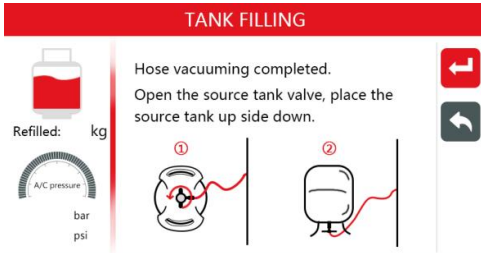

I) Tank filling in progress, please wait.

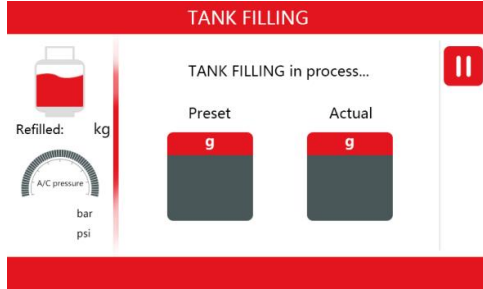

J) The designated amount of refrigerant has been transferred to Tank, please follow the

prompts. Click  to enter next step.

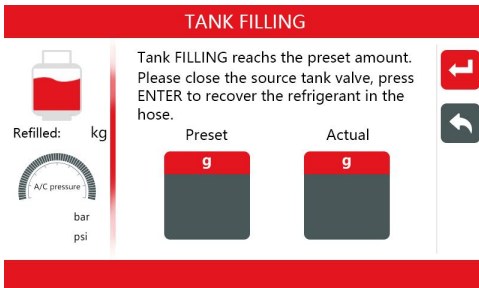

K) Recovering the refrigerant in the hose, please wait.

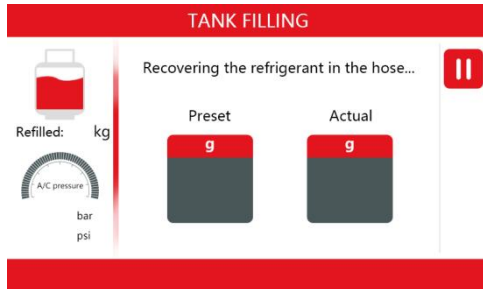

L) Tank Filling completed, initial setup completed.

Click  back to MENU.

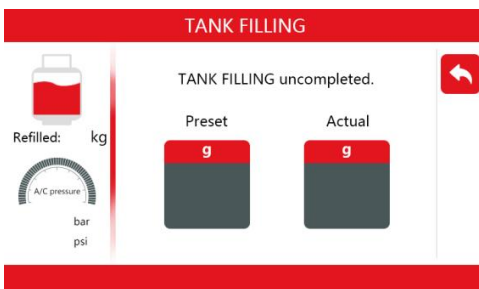

5.Operation introduction

6.AC PRESSRE CHECK:

1)From the MAIN MENU,Click”AC Pressure Check”.

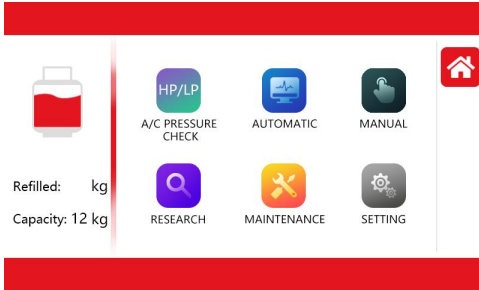

2)Operate according to prompt.,click  to continue.

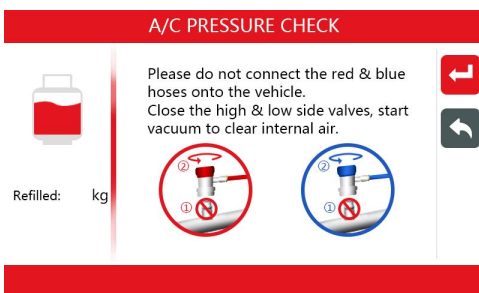

3)Cleaning the hose,please wait.

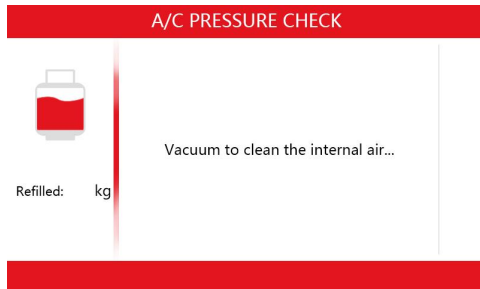

4)Cleaning completed, operate according the

prompt,click  to continue.

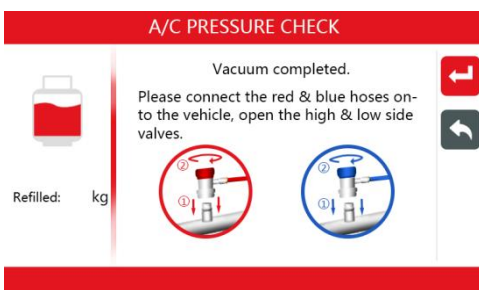

5), Operate according to the prompts, select the program as required.

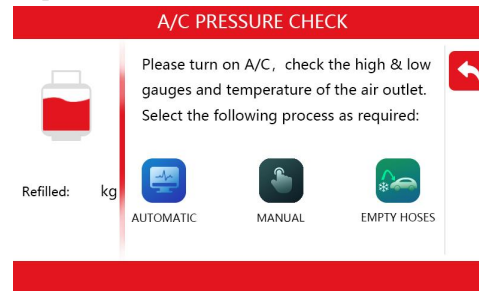

6).Fully automatic operation:, Please refer to the "Fully Automatic Operation" instruction.

7).Manual operation, please refer to "Manual operation" instructions

8).Recovery the refrigerant in hose. Follow the prompts.Click  to continue.

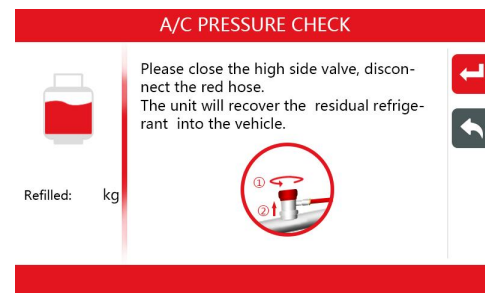

9)、 Recovering the refrigerant into A/C system. Wait.

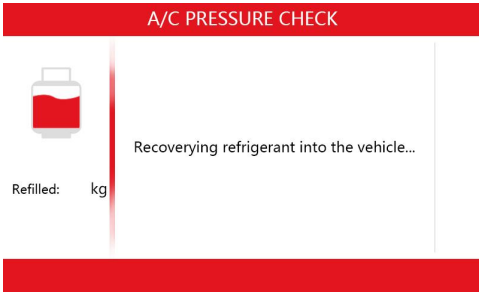

10)、 Follow the prompt, click  to continue.

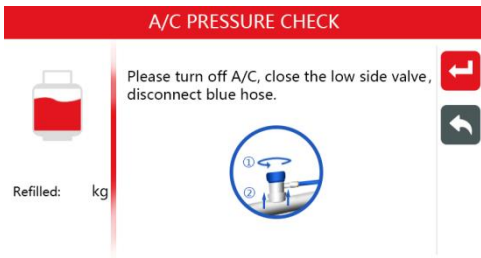

11)、 Recovering the refrigerant in hose. Wait.

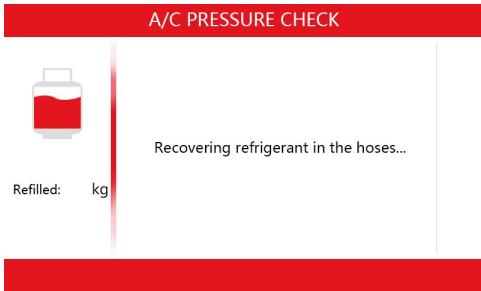

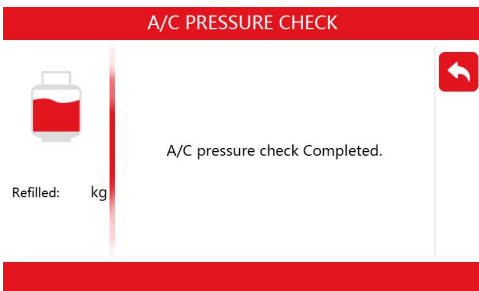

12)、 AC pressure check completed, click  to back to MAIN MENU.



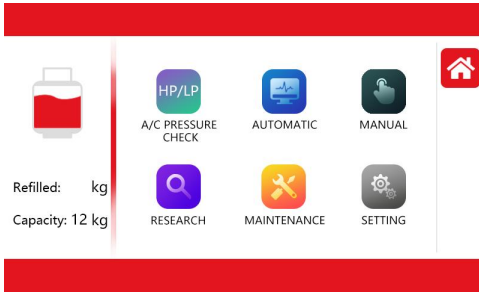

7. Fully Automatic Operation:

A) Select "Automatic".

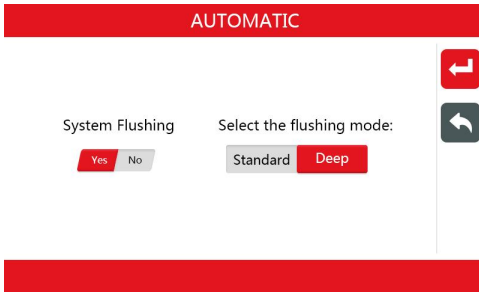

B) Select whether to clean the hose or not. Follow the prompts to set the number of flushing. click  to enter next step.



C) Select whether to recover the refrigerant, select the recovery model, and click  to enter next step.

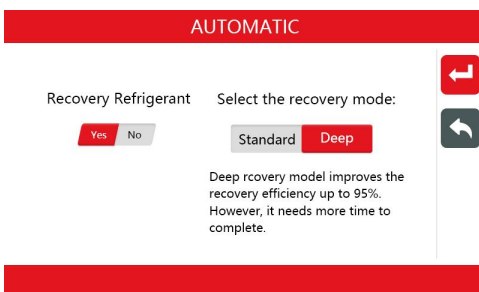

D) Select whether to vacuum or not, and set the vacuuming time, leak check and time of leak detection click  to enter next step.

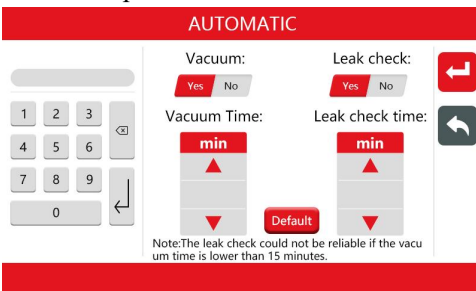

E) Select whether to charge refrigerant or not, and select the charge port and amount. The filling amount can be clicked on "Database" to refer to the options of each model, or click the default value. click  to enter next step.

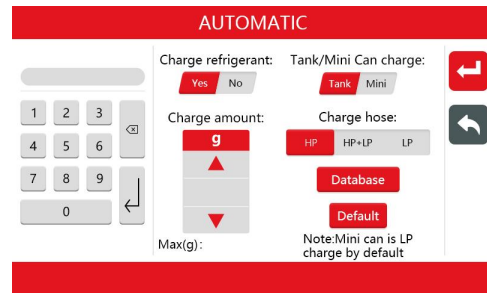

F) Select whether to add compressor oil, click  to enter next step.

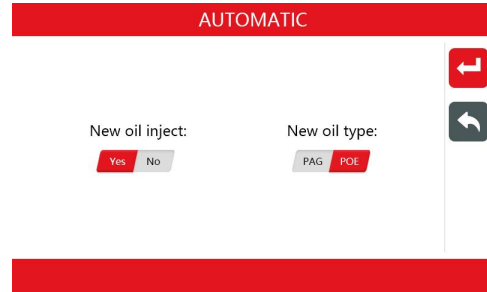

G) Confirm that all settings are correct, then click  to start the progress. If the setting is wrong, please click "Reset" to return to enter the desired value.

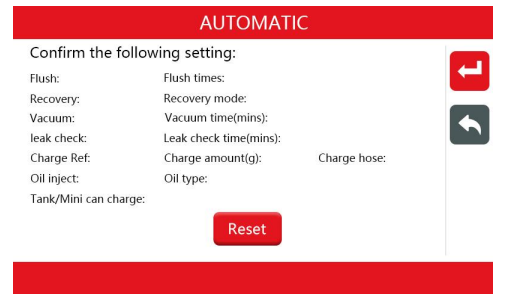

H) Vacuuming the hose if you have selected before. Please wait.

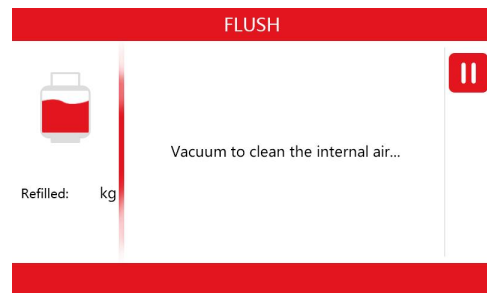

I) Vacuum completed, Please follow the prompt to

operate. Click  to continue.

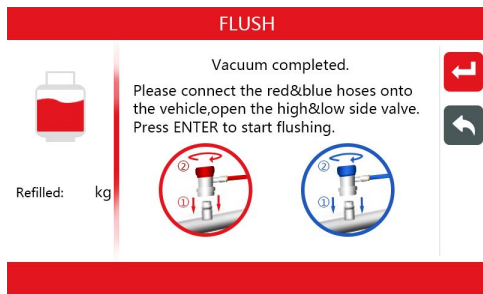

J) A/C flushing program will run if you have selected it. The system will display the forward/reverse cleaning times and duration. Please wait.

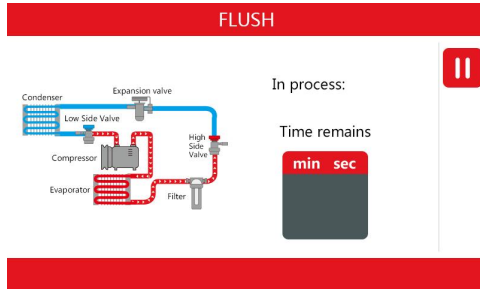

K) Flushing completed, recover the refrigerant in hose. Wait.

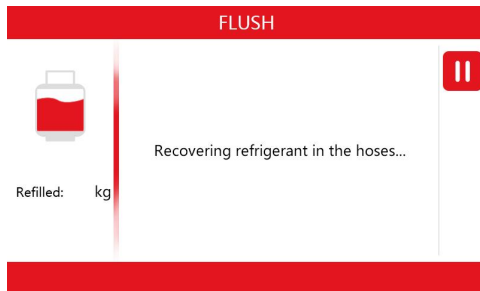

L) Recovery completed, draining the oil, please wait.

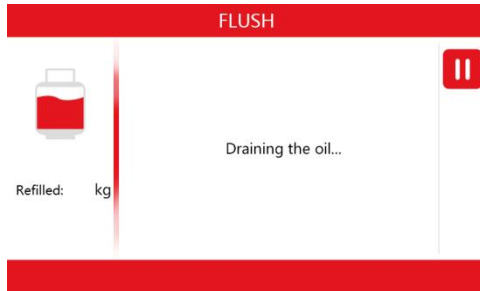

M) Flushing completed, recover the refrigerant in hose. Wait.

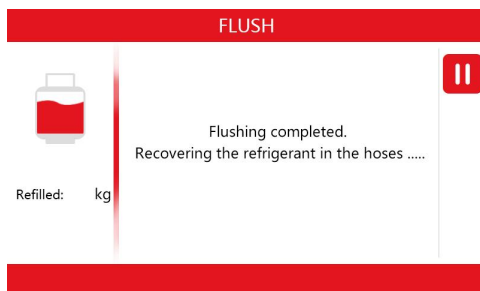

N) Recovery completed, draining the oil. Wait.

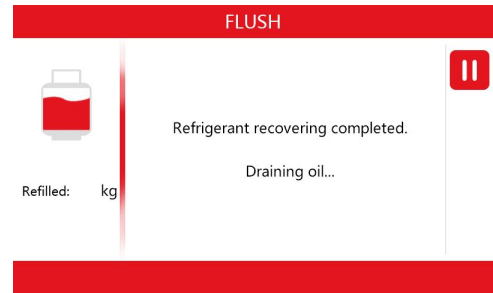

O) Vacuuming the hose, wait.

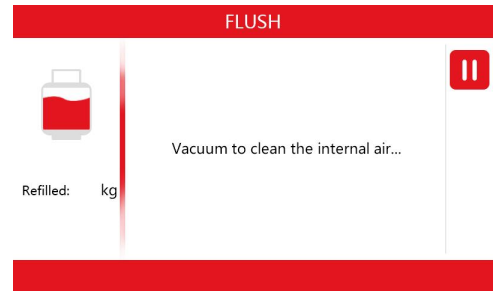

P) Vacuum in progress, leak checking. Wait.

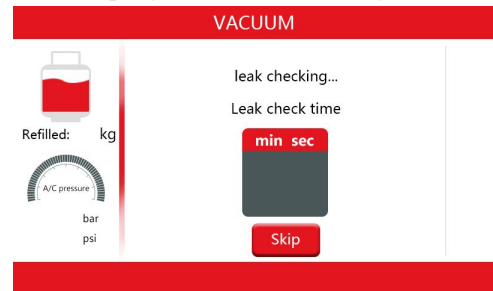

Q) Please follow the prompts and click "Oil inject completed", or skip.

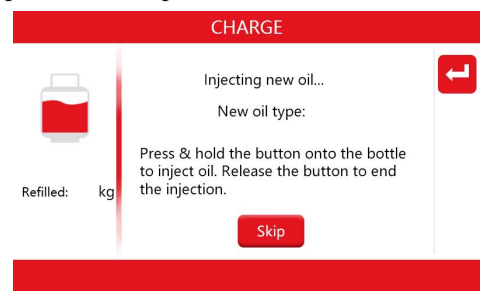

R) Please follow the prompts, click  to continue.

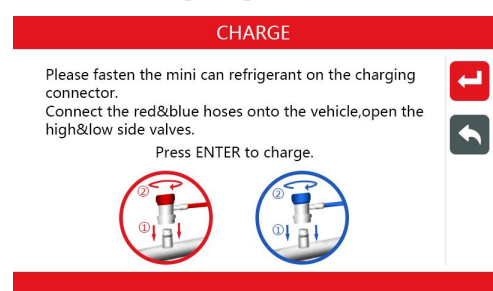

S)The air and impurities in the hose are being exhausted,wait.

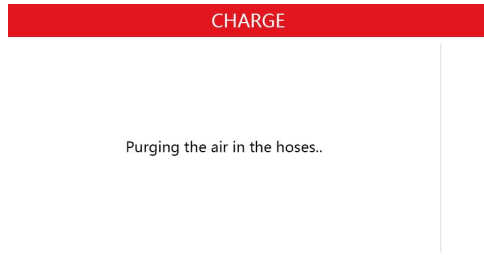

T)Charge is in progress, charging refrigerant.Wait

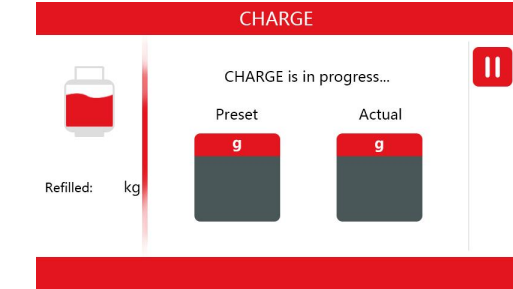

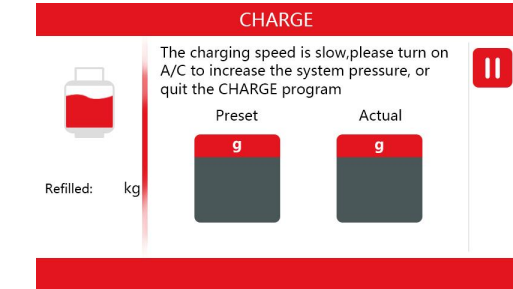

U)Please follow the prompt.

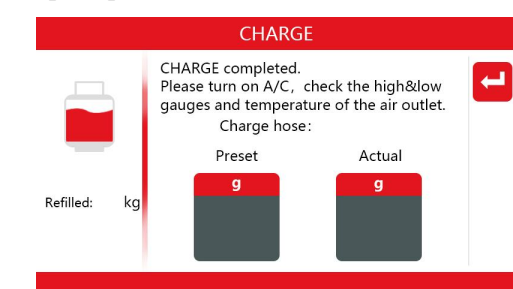

V)Refrigerant Charge completed, operate according to

the prompt, click  to continue.



W)Operate according to the prompt , click  to continue.

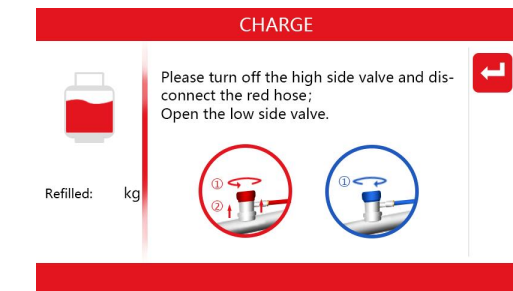

X)Adjusting the pressure,wait.

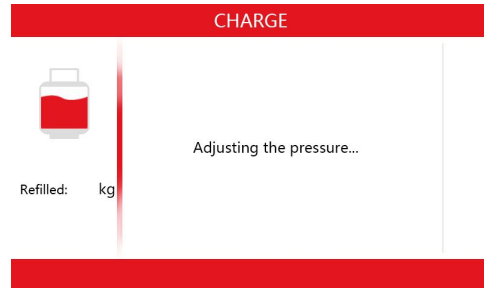

Y)Operate according to the prompt, click  to continue.

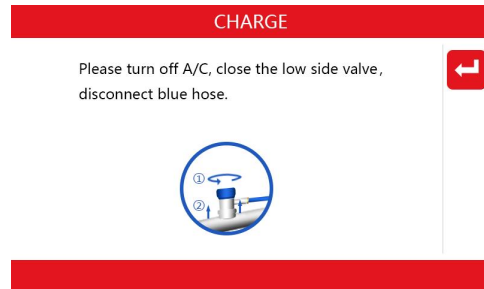

Z)Cleaning the refrigerant and compressor oil in the hose,Wait.

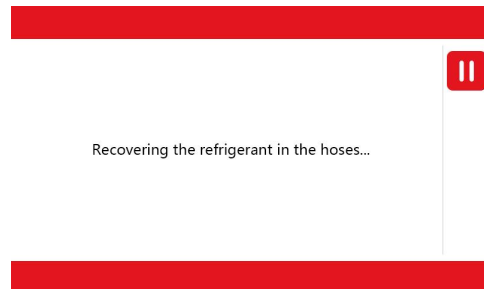

Z-1)The fully automatic operation completed,data can

be observed. Click  to go back to the MAIN MENU.

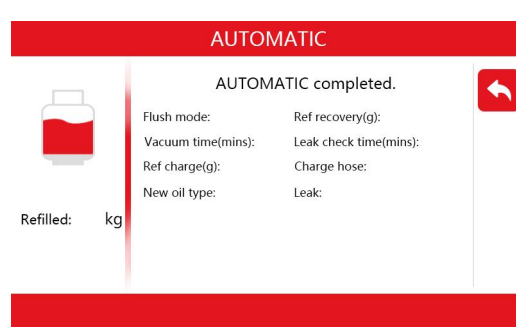

8. Manual operation:

From the MAIN MENU,click "MANUAL"

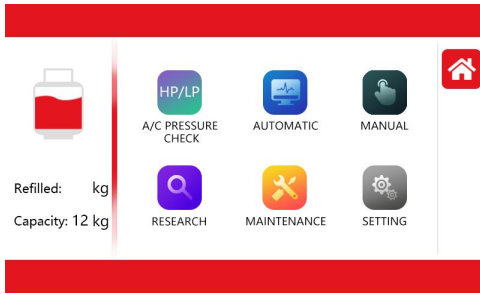

Select according to user's needs.

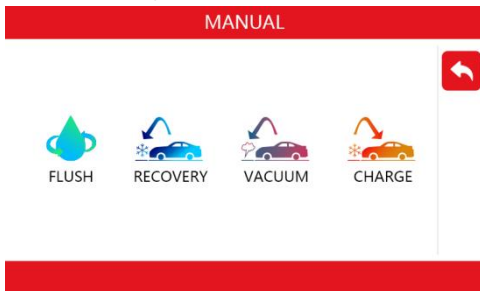

i)Flushing

a.)Please make sure there is more than 3KG refrigerant in the working tank.Please refer to the Source tank filling in the initial setting if not enough.

a.)Click  to enter next step.

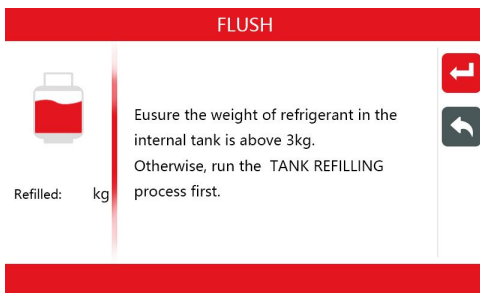

b.) Set the desired flushing times, click  to enter next step.

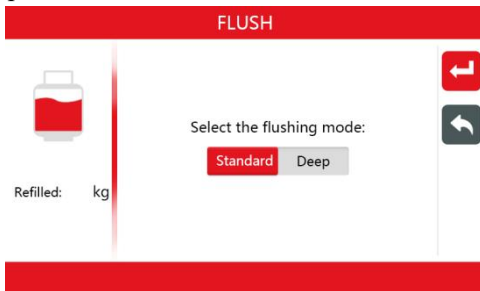

c.) Follow the prompt, click  to enter next step.

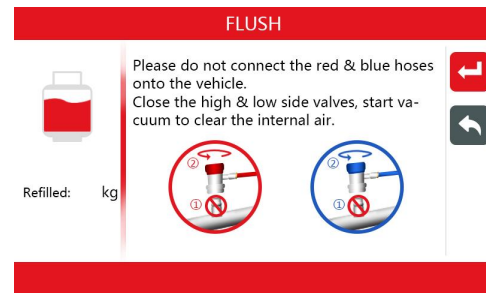

d.) Vacuuming, please wait.

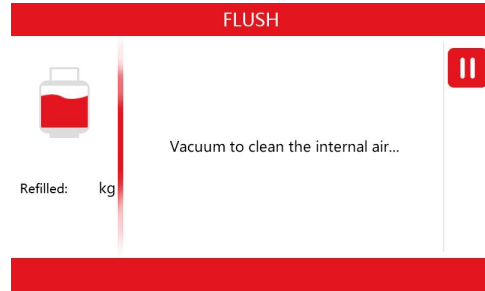

e.) Vacuum completed,Please follow the prompt to operate.Click  to enter next stop.

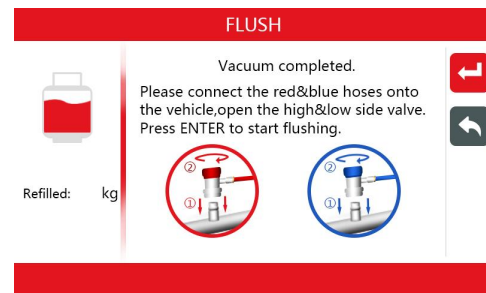

f.) The forward cleaning times and duration will be displayed.

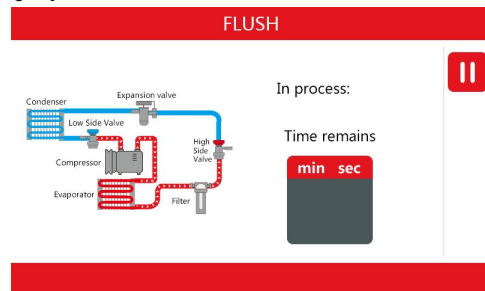

g.) The reverse cleaning times and duration will be displayed.

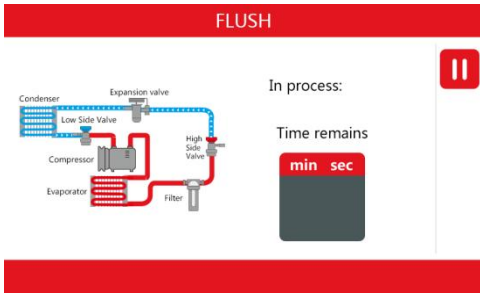

h.) Flushing completed, recovering the refrigerant in hose.
Wait.

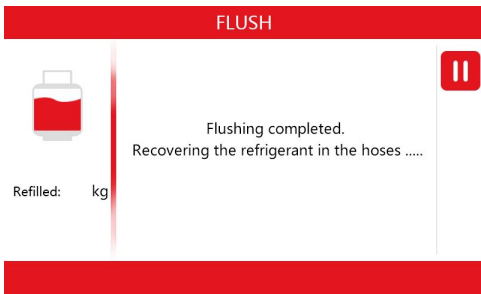

i.) Recovery completed, draining the oil, please wait.

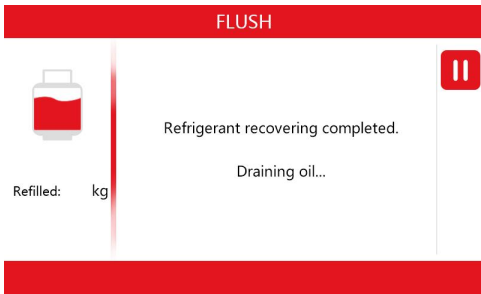

j.) FLUSH completed, the cleaning times can be observed.

Click  to back to the MAIN MENU.

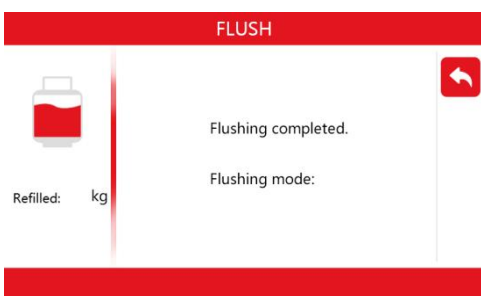

ii.) Recovery

a.) Follow the prompts, select the desired recovery model

"standard" or "deep", click  to enter next step.

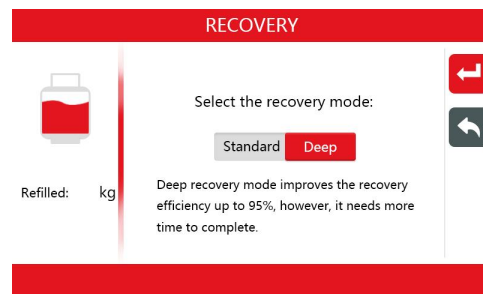

b.) Operate according to the prompts, click  to continue.

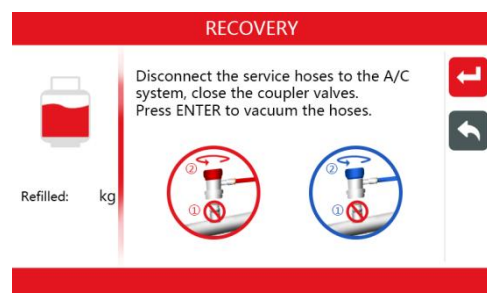

c.) Vacuum completed, operate according to the prompt,

click  to recovery.

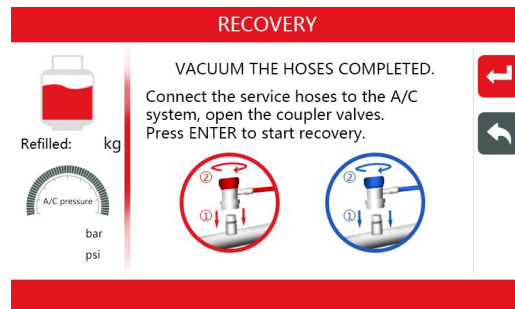

d.) Recovering the refrigerant in AC system. wait.

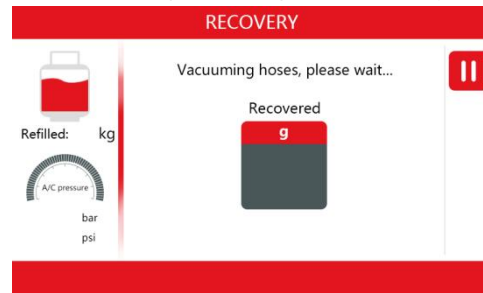

e.) It will take longer time if deep recovery model is selected. Wait.

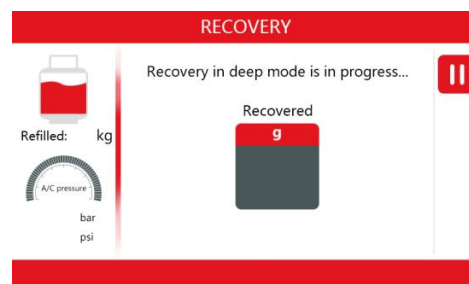

f.) Draining the oil,wait.



g.) Recovery completed. The recovered amount can be printed, click to quit.



iii.) Vacuum

a.) From the MAIN MENU, Click on "VACUUM". Set the desired vacuum time. Please select whether to leak check, if yes, set desired the leak check time. Or click "Defaults".

a.) click to continue.

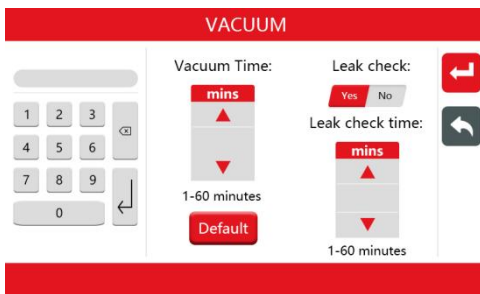

b.) Operate according to the prompt, click to enter next step.



c.) Vacuum is in progress, leak checking, wait

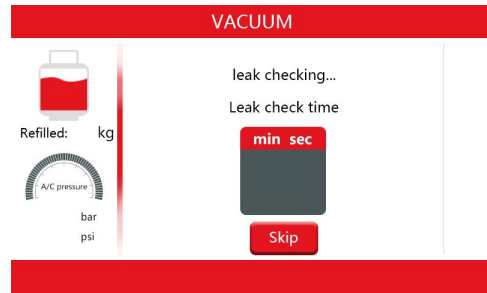

d.) Vacuum completed, data can be printed.

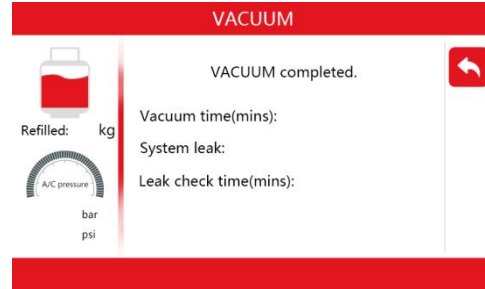

iv.) Charge

From the MAIN MENU, Select "CHARGE". Select charge amount, charge hose. You can set the default value or refer to the database provided. Click to continue.

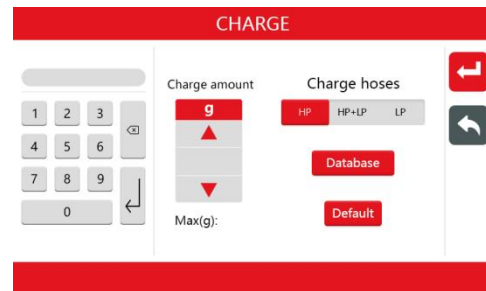

a.) Select whether to add compressor oil and oil type.

Click to continue.

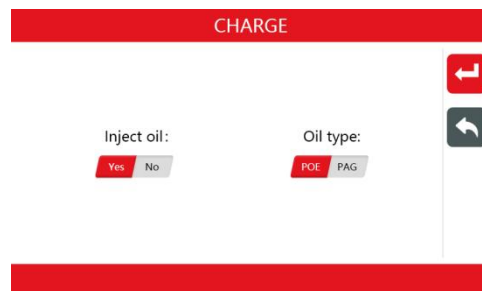

b.) Confirm the settings are correct, and click to continue. Click "Reset" if wrong setting.

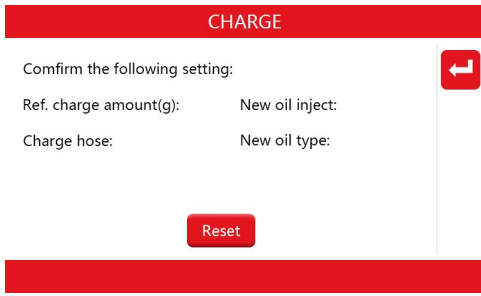

c.) Oil inject is in progress. Wait. Operate according to the prompt. If you don't need to inject oil, click "Skip" to continue.

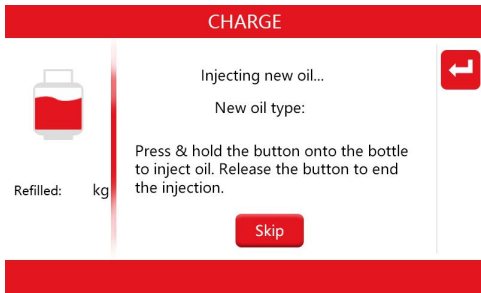

d.) CHARGE is in progress, Wait.

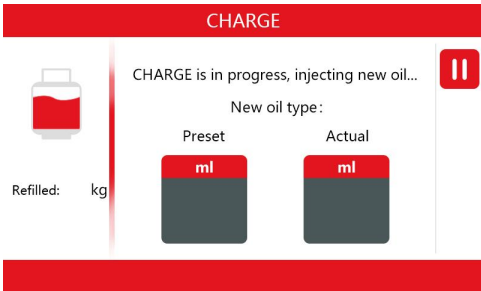

e.) Connect the red & blue hoses onto the vehicle. open the high & low side valves. click  to continue.

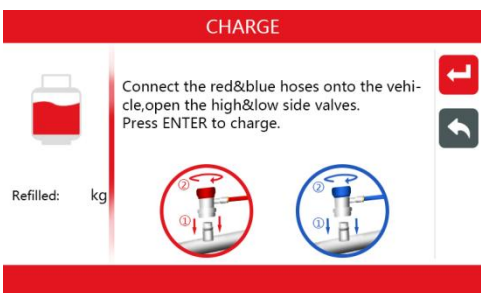

f.) CHARGE is in progress...

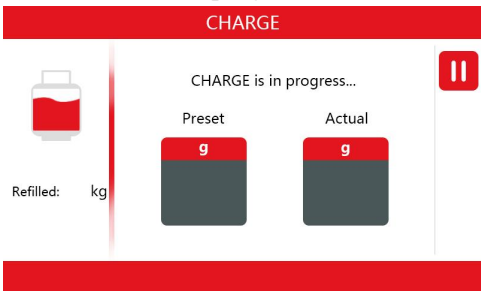

g.) CHARGE completed. Please turn on A/C, check the high & low gauges and temperature of the air outlet

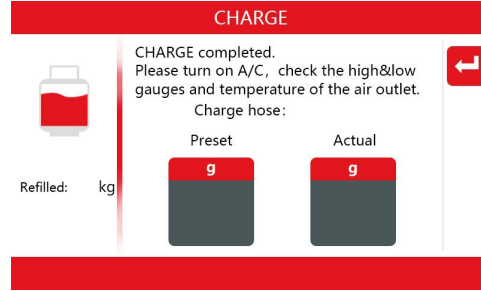

h.) Please turn off the high side valve and disconnect the red hose; Open the low side valve. click  to continue.

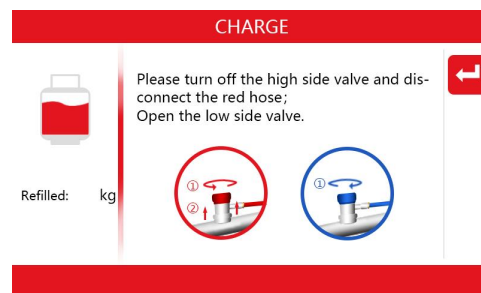

i.) Adjusting the pressure...

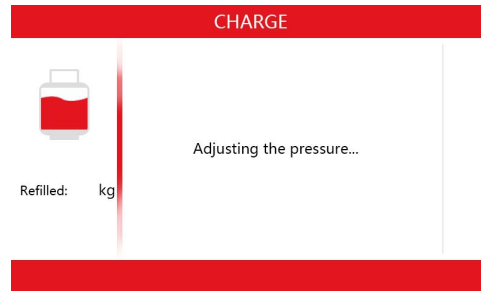

J.) Recovering the refrigerant in the hoses...

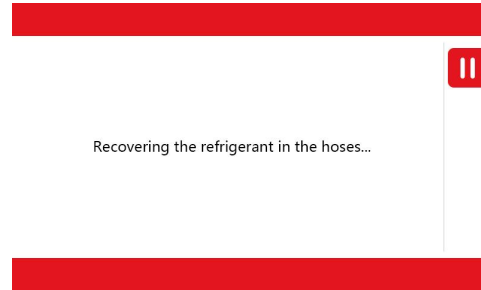

k.) CHARGE completed, data can be printed, click  to exit.

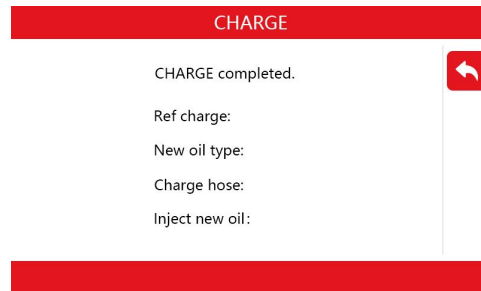

9.Database search

From MAIN MENU,click “RESERCH”.

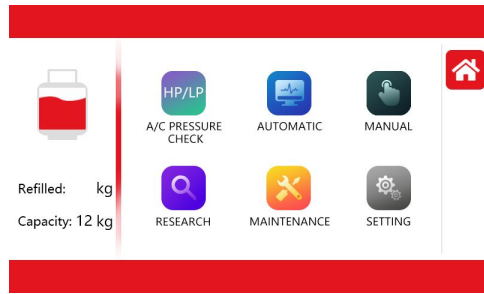

Click“DATABASE”



a.)You can query the charge data for different car series in different countries.

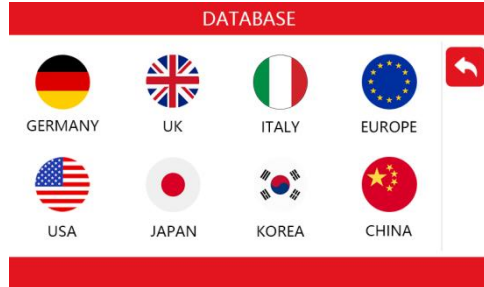

b.)Update database (manufacturer update, no need for users to operate)

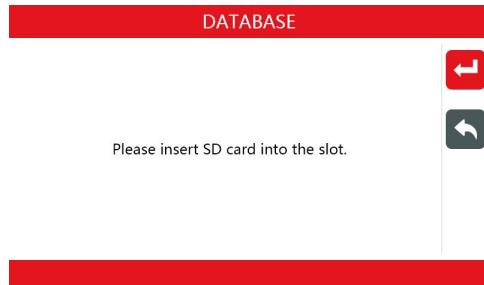

c.)Operation report.

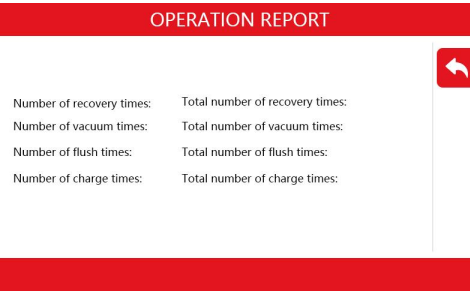

d.)Service Maintenance,Life time of filter and vacuum pump oil will be displayed.

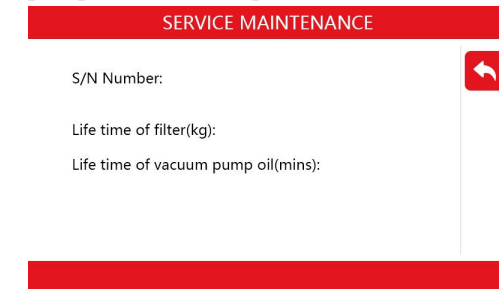

10.Maintenance:

From Main MENU, choose “Maintenance”

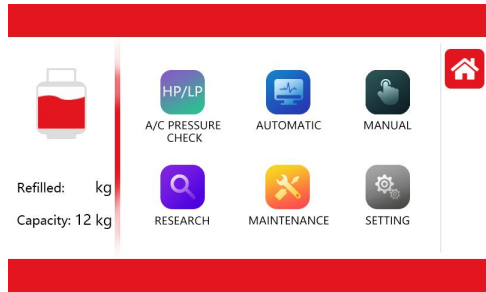

Select the desired program.



1.)CHANGE FILTER,

a.)The remaining filter capacity can be queried.Click  to

change. click  to exit if no need.

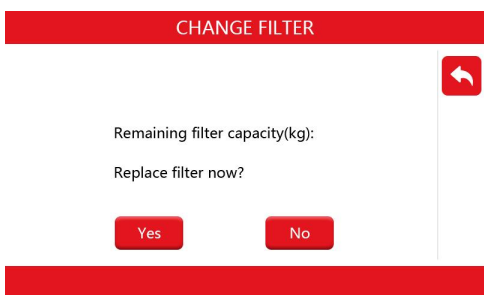

b.)Recovering the refrigerant in the filter.

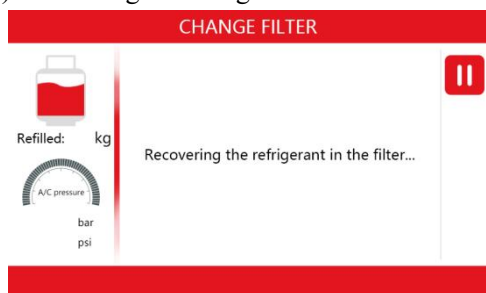

c.)Operate according the prompt, click  to continue.

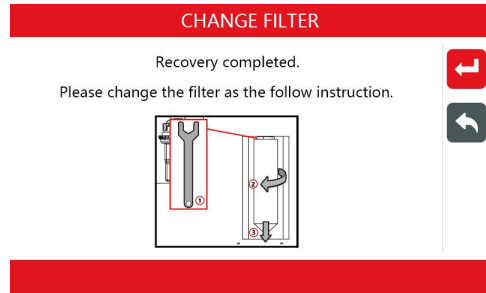

d.)Please ensure the filter had been replaced correctly.Press

 check for leak.

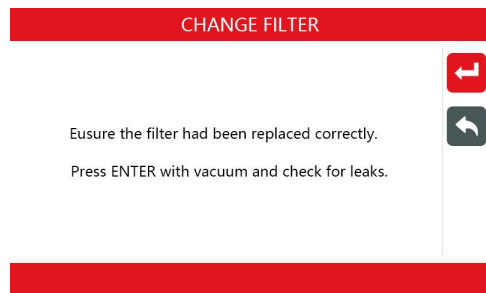

e.)Checking leaks.Wait.



f.)CHANGE FILTER completed, click  to go back to MAIN MENU.

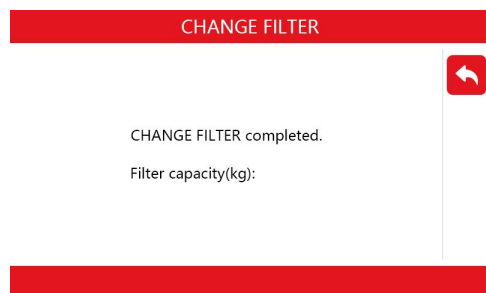

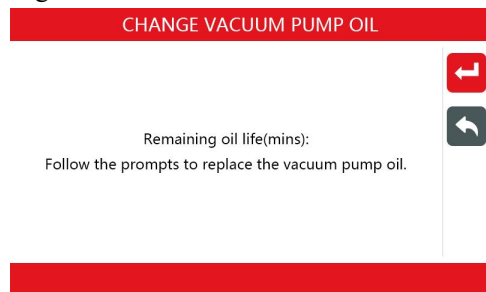

2.)CHANGE VACUUM PUMP OIL

a.)Remaining oil life can be queried, please click  to change oil

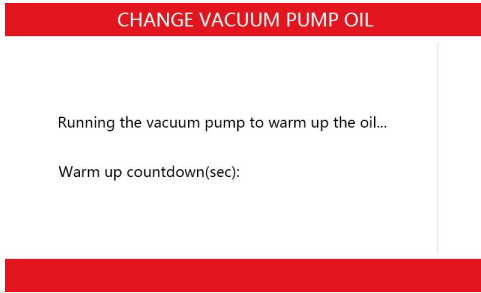

b.)Running the vacuum pump to warm up the oil.Wait.



c.)Please operate according the prompt,click  to continue.

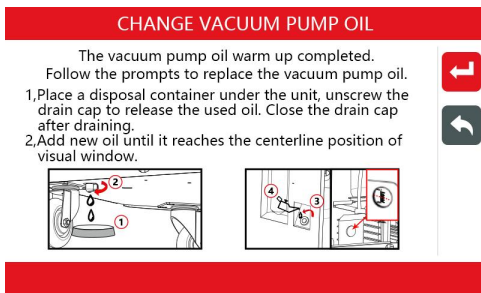

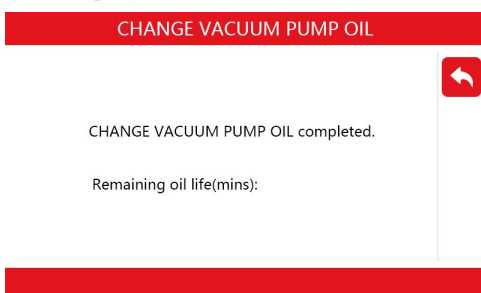

d.)CHANGE VACUUM OIL completed.Remaining oil life will be displayed,click  to exit.

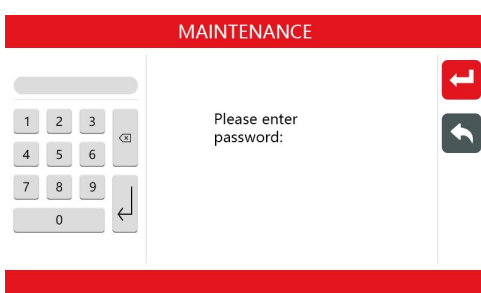

3.)LOAD CELL CALIBRATION

Please contact the manufacturer to get the password before enter the program.Click  to continue.



Please select the calibration mode.Click  to continue.

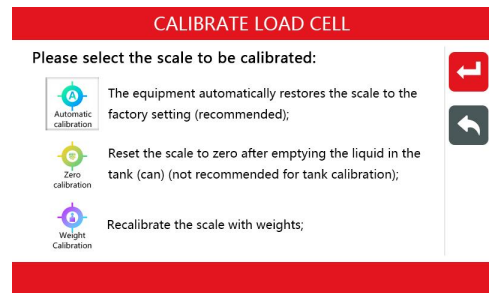

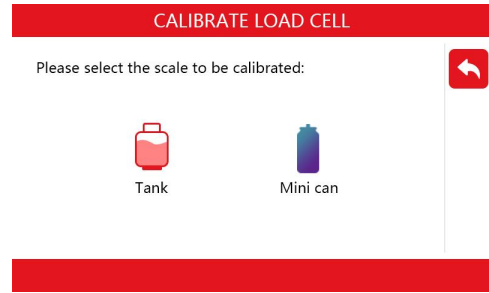

A Automatic calibration

A-1)Please select the scale that needs to be calibrated.

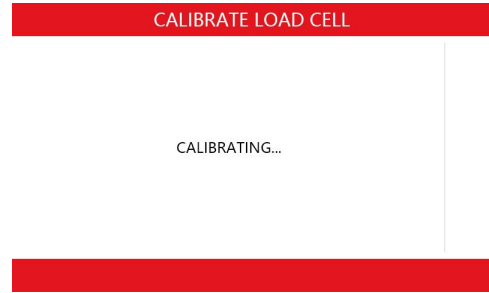

A-2) Calibrating, please wait.



A-3) CALIBRATION completed, click  to exit.

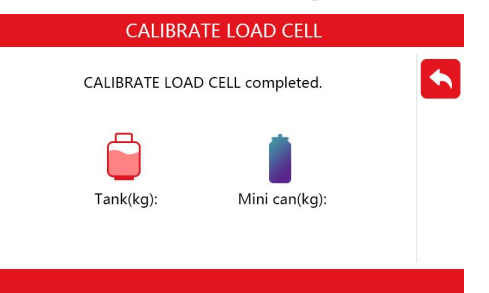

B.Zero calibration, please select the scale to be calibrated,click  to continue.

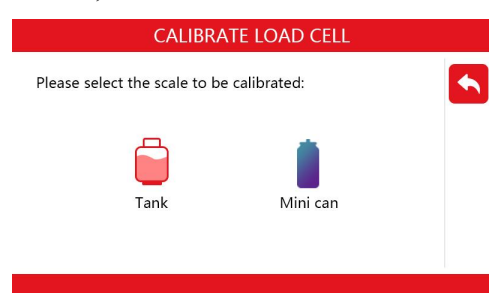

B-1) Select whether to RESET, select "Yes"

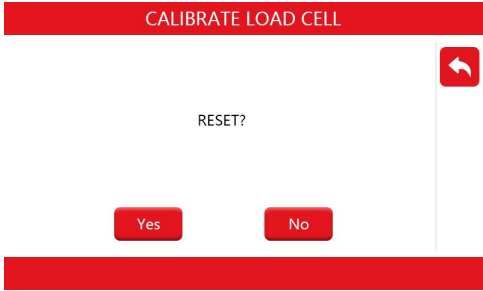

B-2) Calibrating. Please wait.

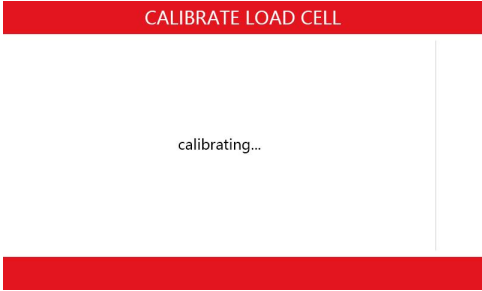

B-3) Calibrate load cell completed. Click to exit.

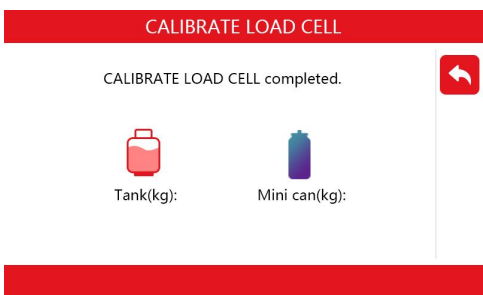

C、 Weight Calibration. Please select the scale to be calibrated.

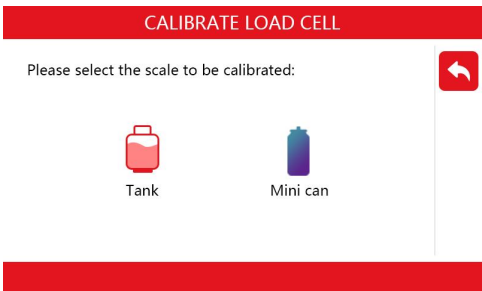

C-1) Weight calibration, prepare a weight and enter the weight of it. click to continue.

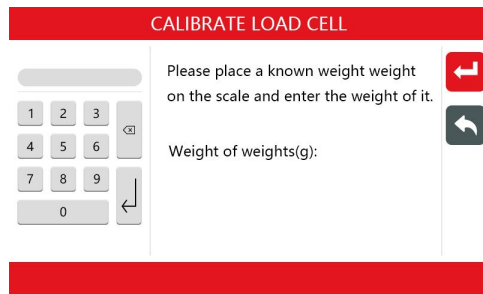

C-2) Operate according to prompt, click to continue.

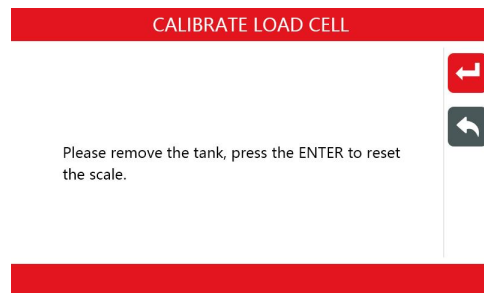

C-3) Operate according to prompt, click to continue

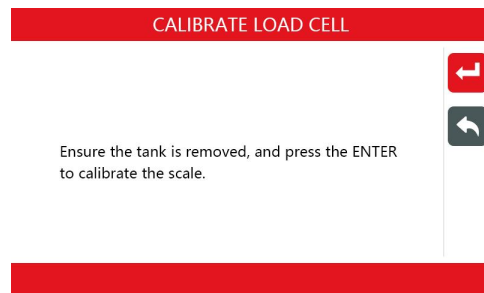

C-4) Calibrating. Please wait.

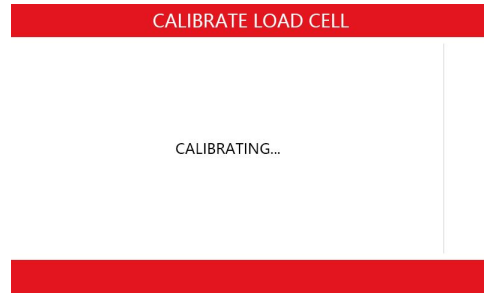

C-5) Calibrate load cell completed. Click to exit.

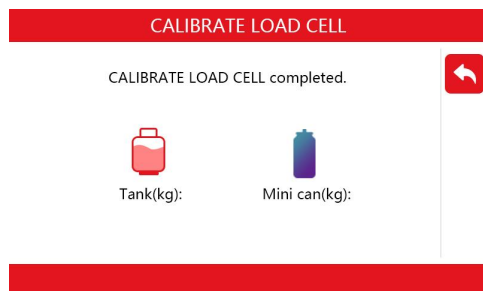

4.) UNIT LEAK CHECK

A) Operate according to the prompt, click  to continue.

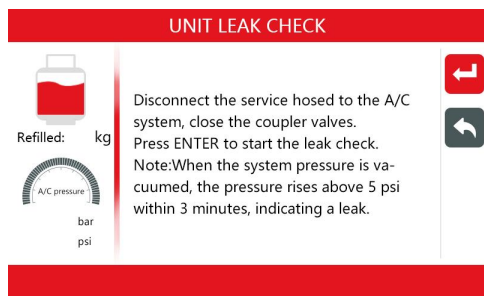

B) Unit leak checking, please wait.





C) Unit leak check completed. Click  to exit.

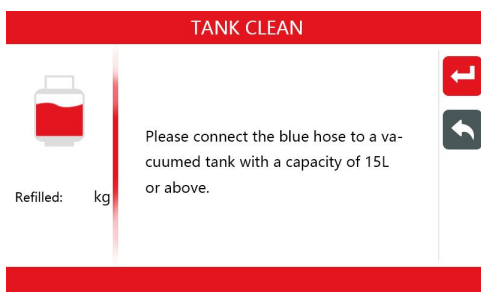

5.) TANK CLEAN

A) Operate according to the prompt, click  to continue.



B) Please set the tank clean weight. Click  to continue.

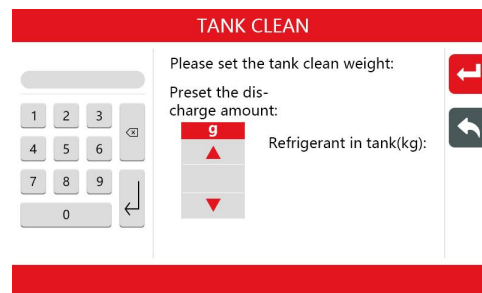

C) Discharging refrigerant in tank. Wait.

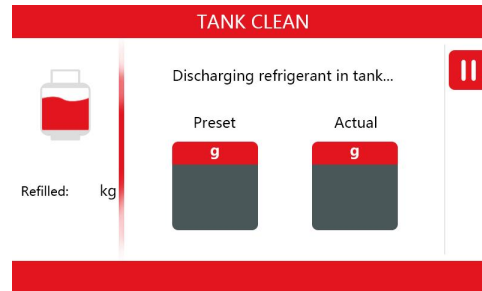

D) TANK CLEAN completed. The preset discharge volume and the actual set discharge volume can be

observed, Click  to exit.



6.) AIR PURGE MANUAL

A) Click , start to purge the air in the tank.

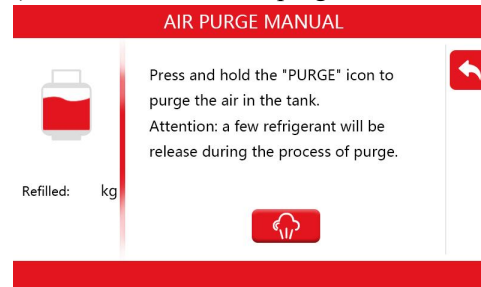

11.SETTING

From MAIN MENU,click “SETTING”.

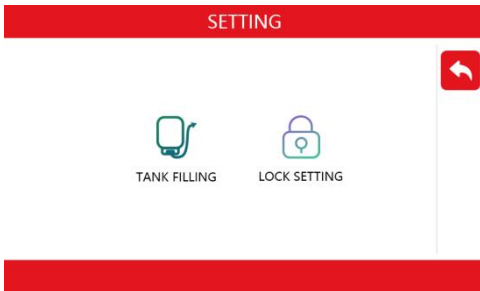



1、 Tank filling,please refer to the initial setting of the source tank filling.

2、 Lock setting.The management password of the unit. For example, if the number of times of use is limited to 50 times, the system will automatically lock, and you need to enter a password to unlock it to continue using it. (Not recommended for regular users)

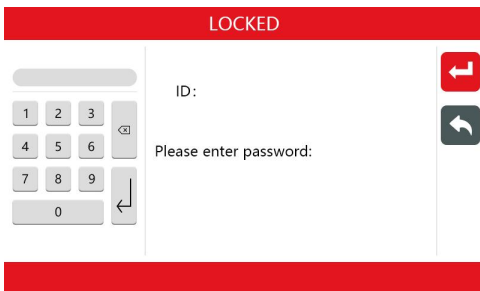

2-1) Input the management password, press  to continue.



2-2) Set the using times for locking, press  will enable the setting.

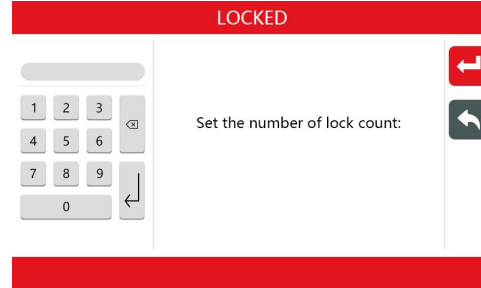

2-3) Block setting successfully.

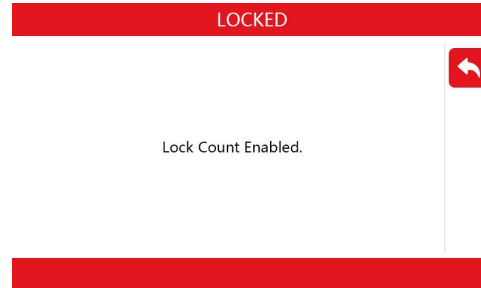

12. Troubleshooting

Display	Cause	Solution
1.RECOVERY FAILED	1.High tank pressure: full tank or poor refrigerant quality	Enter “Maintenance” - Manual Air purge
	2.Aging or damaged compressor	Change
	3.Relay fault	Change
	4.Solenoid valve leakage	Remove dirt or replace with a new solenoid valve
	5.The main board is faulty, recovery failed, but commands such as vacuum and charge can be performed.	Repair
	6.Poor wiring	Check wiring
	7.One-way valve or recovery solenoid valve blocked	Remove dirt or replace with new valve
2.Touch screen FAILED	1. Click the touch screen, no key sound	Replace the touchscreen
	2.Smashed by an object	Replace the touchscreen
	3.The screen does not display as a black screen, it may be a problem with the power supply of the motherboard	Repair the Main board and Check the Screen
	4.There is a key tone interface but no action.	Repair the Main board
3.The electronic scale is not accurate	1.Incorrect operation to zero the recovered refrigerant	Enter“maintenance”-”load cell calibration”-”automatic calibration”
	2.The chassis screws are loose, fix the stability sensor screws, and the liquid storage tank fixing screws are loose	Re-tighten tightening screws
	3.Transportation or loose fixing screws make the wall of the liquid storage tank contact other parts of the equipment	Tighten the fixing screws of the weight after adjustment,
	4.If you disassemble and repair without permission, you should pay attention to the arrow direction of the electronic scale is downward.	If it is installed in reverse, it needs to be adjusted and corrected
	5.Damaged load cell	Change
	6.Damaged main board	Repair
4.Charge FAILED	1.The refrigerant in the internal tank is less than 1kg	Recovery more than 1KG of refrigerant to the tank
	2.Fill Mini can refrigerant to the tank.	Some technicians fill mini can of refrigerant (refrigerant with a weight of less than 1KG) to the internal tank.This approach is wrong.Internal Tank should be filled with a standard source tank

		((usually weight 13.6KG)
	3. Filling valve is blocked or valve core is damaged	Clean or replace
	4.Damaged main board	Repair
	5.Manually close the hand valve of the internal tank	Reopen
	6.Incorrectly setting the filling amount to "zero"	Reset
5.VACUUM FAILED	1.Vacuum pump failure	Change
	2.Relay failure	Change
	3.Damaged main board	Repair
	4.Prompt that the pressure of the hose is too high and cannot be vacuum	Recovery or manually deflate the external hose to less than 0.5KG/CM2
	5.Can not maintain pressure for leak detection	1.Check A/C system for leaks 2.Whether the quick connector and hose of the refrigerant machine leak, or the leak of the vacuum pumping piping. 3.Check PAG POE and UV solenoid valve for leakage
	6.Filling valve leaks	Change
6.Smoky vacuum pump	1.The vacuum pump oil is deteriorated	Change
	2.Excessive vacuum pump oil, which accumulate vacuum pump oil in the vacuum pump for a long time when vacuuming the A/C system .	Drain oil from vacuum pump to middle scale line
	3 The connector of the pipes may be loose and ,which may cause smoke.	Check and tighten the relevant connector.
	4.The vacuum time is too long, and the heat will cause the vacuum pump oil to evaporate.	Ignore
	5.Car A/C systems keep too much gas for a long time The vacuum pump fixing screw is loose	Ignore
7.Noisy vacuum pump	The vacuum pump fixing screw is loose	Re-fasten the screws